

Each DATAOUT Xilinx is connected to eight ASICs, on the opposite side of the card, via two tri-state busses, as shown.

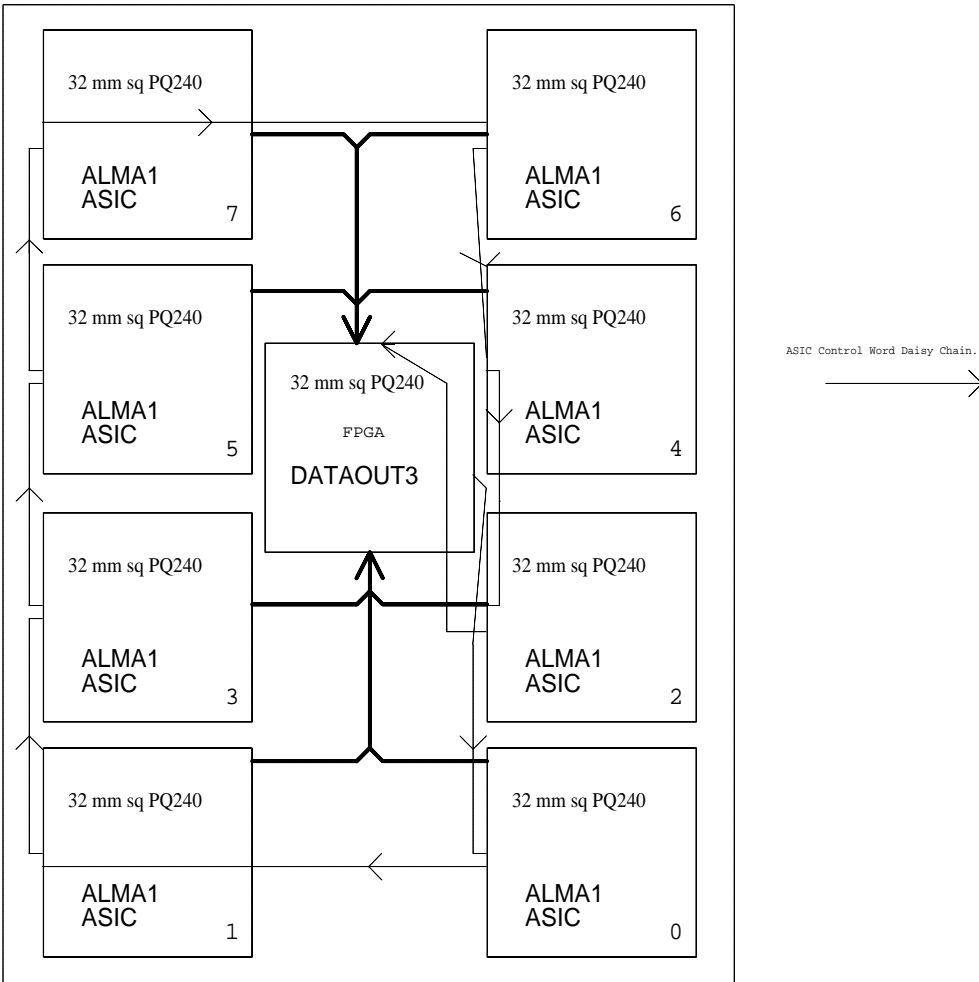

Control Words loaded in bottom ASICs first to allow for a partially populated card, with only the bottom row. Have vias positions such that a jumpers are possible from nets CD2 to CD8, and from CC2 to CC8.

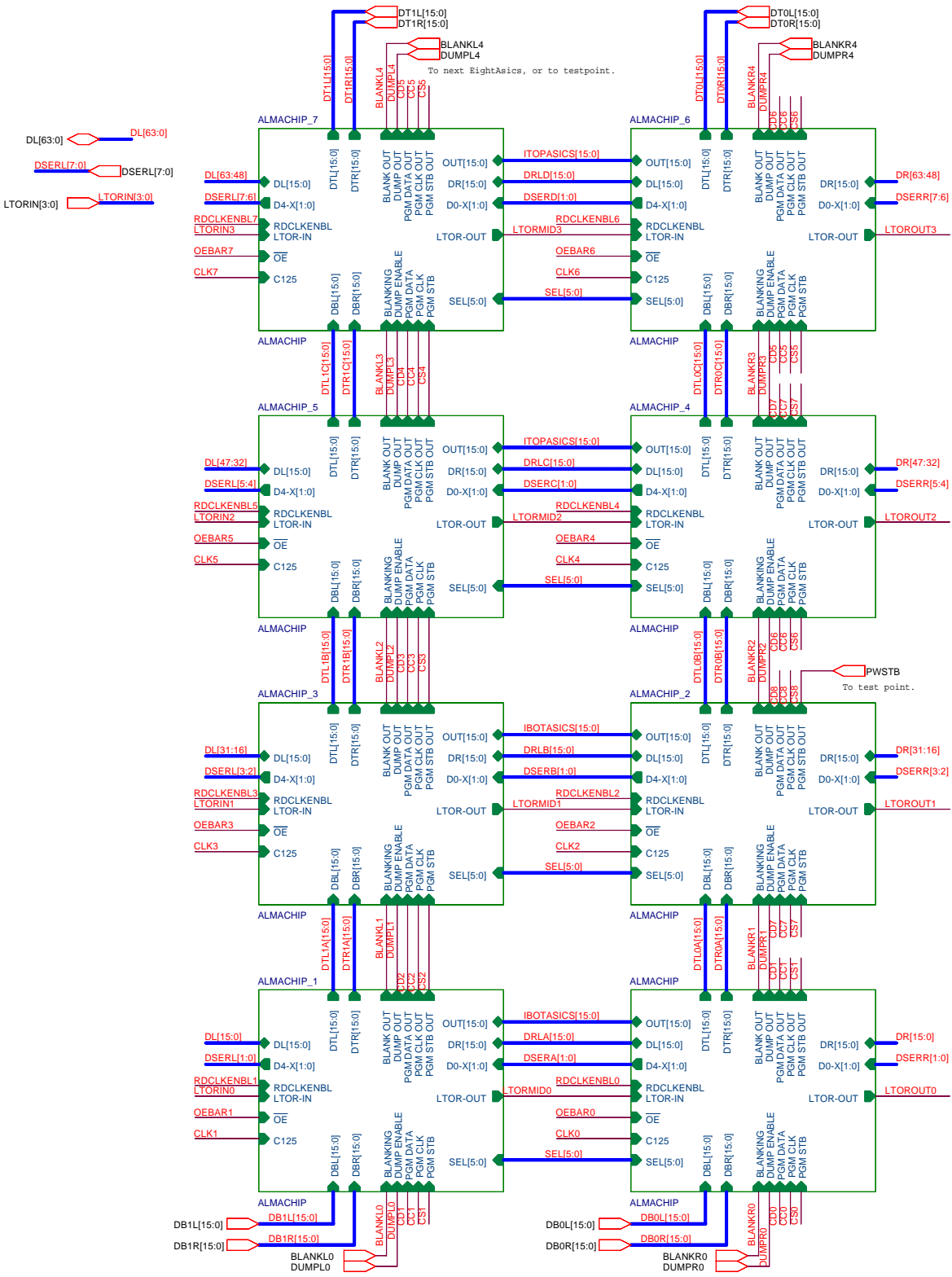
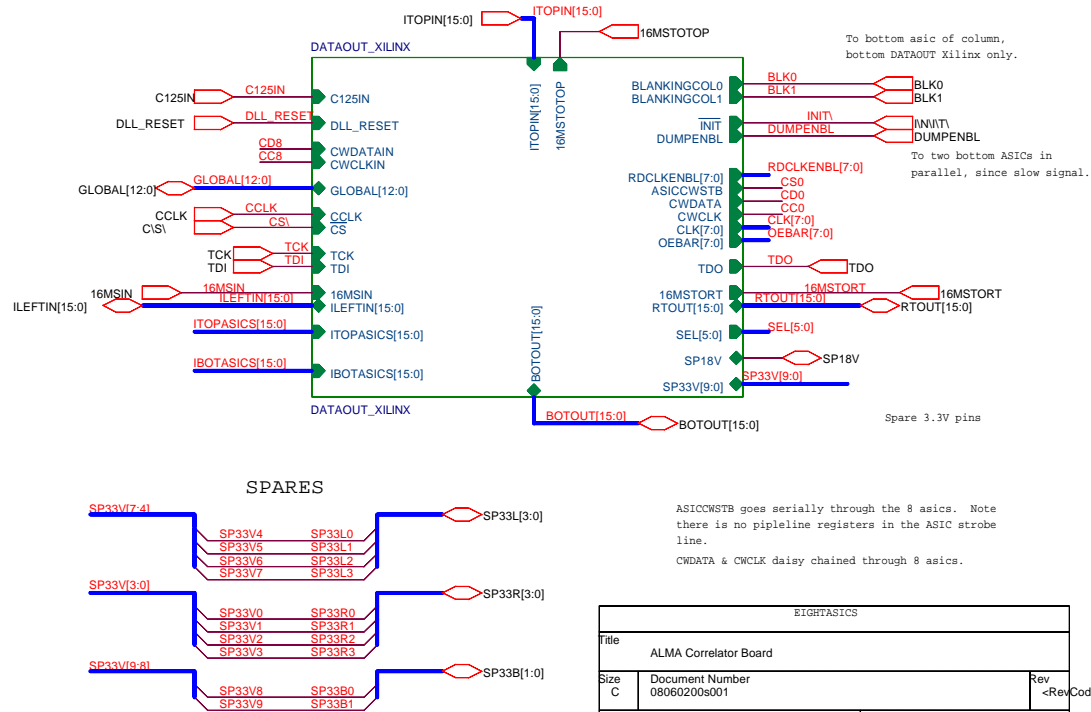

EIGHTASICS	
Title	ALMA Correlator Board
Size	C
Date	Thursday, June 14, 2001
Document Number	08060200a001
Rev	<RevCode>
Sheet	107 of 133