

MILLIMETER ARRAY

MEMO NO. 114

**An integrated SIS mixer & HEMT IF  
amplifier**

S. Padin

California Institute of Technology

Owens Valley Radio Observatory

PO Box 968, Big Pine CA 93513

Tel (619) 938-2075 ex 101

FAX (619) 938-2297

e-mail [spadin@caltech.edu](mailto:spadin@caltech.edu)

## 1 Introduction & summary

This report contains some initial results of computer modelling an integrated SIS mixer and HEMT IF amplifier. The integrated approach represents a departure from the usual millimeter-wave SIS receiver configuration where the SIS mixer and IF amplifier are quite separate circuits coupled through a  $50 \Omega$  interface. The traditional approach makes for easy testing since the mixer and IF amplifier can be separated. However, a matching circuit is required at the IF amplifier input and a circulator or some matching circuit must be provided at the mixer output. These circuits contribute loss ahead of the IF amplifier and restrict the receiver IF bandwidth. In the integrated SIS mixer and IF amplifier most of the matching components are eliminated so the approach has potential for improving the receiver noise temperature and increasing the IF bandwidth. The integrated receiver also offers a substantial size reduction which may be important for focal plane array applications.

I have modelled integrated receivers based on two existing 230 GHz SIS mixers which were developed at CfA and NRAO. Both mixers have given receiver noise temperatures in the 25 to 30 K range in traditional receivers with  $50 \Omega$  IF amplifiers, and both operate with  $\sim 0$  dB gain. The integrated receiver performance is similar for the two mixers, but the NRAO mixer gives wider IF bandwidths because of its lower IF port capacitance. With a Fujitsu FHR02X HEMT device coupled to the SIS substrate via a small inductance, the receiver noise temperature is close to the mixer  $T_{\min}$  over a 0.5 to 4 GHz IF band. Substituting InP HEMTs (which are being manufactured for NRAO by Hughes) dramatically reduces the IF noise contribution and increases the IF bandwidth to  $\sim 5$  GHz for the CfA integrated receiver and  $\sim 8$  GHz for the NRAO integrated receiver.

The mixer details for this work were provided by Ray Blundell and Tony

Kerr. Marian Pospiesalski provided the HEMT models and David Woody provided the SIS junction parameters.

## 2 Modelling strategy

Modelling an integrated receiver presents special problems because while analysis software is available for both SIS mixers and microwave amplifiers, no single (affordable) package conveniently handles both devices. For this work I decided to use a commercially available linear microwave analysis package (MMICAD) because this environment provides all the tools which are needed to investigate different IF amplifier circuits. As far as noise analysis is concerned MMICAD is basically restricted to 2-ports, but the simplest model of an SIS junction is a 3-port (signal, image and IF). To deal with this, I used the array of 2-ports shown in Fig. 1 to synthesize a 3-port junction model. The model input parameters are 3-port  $y$  and noise correlation matrices computed from the junction I-V curve using software written by Woody & Wengler. Unfortunately MMICAD cannot deal directly with the noise correlation matrix elements so a MATHCAD file is used to compute the 2-port noise parameters  $F_{\min}$ ,  $R_n$ , and  $Z_{opt}$  for each 2-port in the junction model. The quantum noise is added to the correlation matrix elements in the MATHCAD file and here I assume that the signal and image admittances are always equal to the junction normal conductance. This is not correct and results in an overestimate of the quantum noise for signal and image conductances less than the normal conductance, and an underestimate of the quantum noise for signal and image conductances greater than the normal conductance. Fixing the image termination in the 3-port model of Fig. 1 reduces the junction to a 2-port which allows us to proceed with the 2-port noise analysis available in MMICAD. Fig. 2 shows noise and gain circles generated by MMICAD and corresponding circles from the Woody & Wengler software which was used to

calculate the  $y$  and noise correlation matrices. The incorrect quantum noise calculation is obvious but the MMICAD model is nevertheless a good approximation. The IF port admittance predicted by the MMICAD model is also in good agreement with the Woody & Wengler software. While the MMICAD model can almost certainly be improved, in its current form it is adequate for investigating performance tradeoffs in an integrated receiver. In any case, I suspect that variations from one junction batch to another will exceed the model errors. Incidentally, the model parameters for Fig. 2 are for a  $8000 \text{ A cm}^{-2}$  JPL Niobium junction at 230 GHz. This same junction model, with the normal resistance as a model variable, was used for all the design work presented here.

### 3 IF amplifier

The IF amplifier design is driven primarily by the need to reduce matching circuit losses and increase the bandwidth. These considerations suggest a simple circuit mounted very close to the SIS junction. The junction IF port impedance is typically a few times the normal resistance while the optimum source impedance for a  $200 \mu\text{m}$  HEMT is  $\sim 100 + j150 \Omega$  at L-band and both real and imaginary parts decrease with increasing frequency. Thus, a junction can be coupled to a HEMT with just a series inductor, the inductance and junction normal resistance being chosen to minimize the HEMT noise at the desired IF frequency.

In an integrated receiver the source impedance for the IF amplifier varies over a wide range so it is important to guarantee unconditional stability. This is usually done by adding a shunt resistor at the HEMT drain. Adding inductance in the HEMT source also improves the stability but increases the amplifier input impedance and as a result makes the junction more susceptible to saturation. For the models presented here I used a small source inductance



(0.15 nH) because this allows a larger stabilizing drain shunt resistance which results in a higher IF amplifier gain. Fig. 3 shows the basic IF amplifier circuit and HEMT parameters which I used in the integrated receiver models.

The bandwidth of the IF amplifier is determined primarily by the low pass filter consisting of the series inductor at the amplifier input and the HEMT gate capacitance. For a Fujitsu FHR02X HEMT and a 10 nH inductor the bandwidth is  $\sim 4$  GHz. The bandwidth can be increased either by using a smaller HEMT to reduce the gate capacitance or by reducing the gate inductance. Since both approaches also change the optimum source impedance for the IF amplifier, there is some compromise between bandwidth and receiver noise temperature.

#### 4 Junction bias tee

I had initially intended to make the junction bias tee, IF amplifier and mixer separate sub-assemblies that could be bolted together with k-connector style interfaces. (Or at least have a separate IF amplifier.) However, I found that increasing the physical separation between the mixer and IF amplifier increased the receiver noise temperature in some parts of the IF band. This is a result of the mismatch between the mixer and IF amplifier causing the mixer gain and hence the IF contribution to the receiver noise temperature to vary across the IF band. The effect is significant because the IF amplifier does not always see the optimum source impedance so the IF noise temperature is high, at least in parts of the band. Unfortunately, adding just a single k-connector bead (55 mil long) at the mixer output has a significant effect on the receiver noise temperature. I also found that increasing the mixer IF port shunt capacitance made the problem worse. As a result of these observations I abandoned the idea of a receiver made of separable sub-assemblies and to minimize the mixer IF port shunt capacitance I decided to avoid microstrip

structures in the bias tee and IF amplifier. This basically limits the construction technique to wirebonded lumped components. Since air core inductors are difficult to wirebond I'm considering spiral chip inductors which are manufactured with pads for wirebonding. The entire circuit is then composed of various chips which are glued or soldered to the receiver block and all connections are wirebonded. Spiral chip inductors have lower Q than air core inductors but this may actually be an advantage since the larger resistance implies poorer thermal conductivity which will help to thermally isolate the junction from the bias resistors and HEMT.

Fig. 4 shows a model of the junction bias tee. This is a very simple series capacitor and parallel inductor arrangement but the circuit looks complicated because I have made some attempt to model the parasitics of the chip components. The dc arrangements are appropriate for a 6-wire bias circuit. There is a  $20\ \Omega$  resistor across the junction at dc to ensure stability and all the bias wires have series  $10\ \text{K}\Omega$  resistors to protect the junction.

## 5 Integrated receiver based on a CfA 176-256 GHz mixer

Fig. 5 shows the model details for an integrated receiver using a CfA 176-256 GHz mixer and IF amplifier and bias circuits as described above. The lossless input matching circuit is an idealized representation of the RF part of the receiver and presents the optimum signal impedance,  $Z_{sigopt}$ , to the junction. The image termination is fixed at  $Z_{sigopt}^*$  which is appropriate for a double-sideband receiver. For this model I've assumed that one end of the junction is bonded directly to ground but in fact the suspended stripline is symmetrical so the IF model is missing a short length of line and this will result in a slight underestimate of the receiver noise temperature. Since this receiver is based on an existing mixer, the junction normal resistance is not really available as a model variable. However, it turns out that the  $22\ \Omega$  junctions in the

CfA design are close to optimum for the model. Fig. 6 shows the receiver noise temperature and gain for various values of the HEMT gate inductance. There is obviously a compromise here between IF bandwidth and receiver noise. This is another feature of the mixer to IF amplifier mismatch problem that forced me to shrink the bias tee. Despite the mismatch problem, good receiver performance over an IF bandwidth of  $\sim 4$  GHz can be attained with an FHR02X HEMT. Changing to an InP HEMT improves the performance dramatically as shown in Fig. 7. In this case the HEMT is a  $300 \mu m$  device. The bandwidth is similar to that with a FHR02X ( $200 \mu m$ ) HEMT but the receiver noise is much improved. This is because the IF noise temperature is now very small and the IF contribution to the receiver noise is negligible even in those parts of the band where the mixer gain is low. Using a smaller InP HEMT increases the IF bandwidth but also increases the receiver noise because the HEMT source impedance is far from optimum.

## 6 Integrated receiver based on an NRAO 200-300 GHz mixer

Fig. 8 shows the model details for a receiver using an NRAO 200-300 GHz mixer (SIS 373). Again I've assumed that one end of the junction is connected directly to ground, which in this case is a good approximation because the IF return is via two short ( $\lambda/4$  at RF) stubs very close to the junction. The performance for this receiver is shown in Figures 9 and 10 for various HEMTs and the same  $22 \Omega$  junction used in the previous section. In general the NRAO integrated receiver gives wider IF bandwidths and lower receiver noise temperatures than the CfA integrated receiver. This is because the NRAO mixer IF port capacitance is lower and the junction substrate is shorter so the mixer is better matched to the IF amplifier. The NRAO mixer gives a reasonable noise match even for small HEMTs. Thus, a receiver with a  $50 \mu m$  InP HEMT has good noise performance over an IF bandwidth of  $\sim 8$  GHz.

## 7 Thermal considerations

Integrating an SIS mixer and HEMT IF amplifier in the same block is clearly advantageous from an electrical point of view but power dissipation in the amplifier is a problem. For an FHR02X HEMT the power dissipation is  $\sim 10$  mW so the SIS junction must be very well decoupled thermally from the HEMT. Unfortunately this is somewhat in conflict with the electrical constraints which demand that the junction and HEMT be close together. This issue is far from resolved, but my initial idea is to use the HEMT gate inductor as a high series thermal impedance and the bias tee coupling capacitor as a low shunt thermal impedance. The spiral chip inductors I mentioned earlier are probably poor thermal conductors, though this is yet to be confirmed. A thermal shunt can be provided at the bias tee capacitor by mounting it on crystalline quartz or perhaps diamond. (I've always wanted to build a circuit with a diamond!) Unfortunately, the capacitor must be mounted on something fairly thick to minimize the mixer IF port capacitance. The thermal management issue disappears if InP HEMTs are used since the power dissipation is lower by an order of magnitude.

## 8 Conclusions

MMICAD models of integrated receivers based on CfA and NRAO 1 mm mixers with compact wirebonded FHR02X HEMT IF amplifiers, indicate that noise performance close to the mixer  $T_{\min}$  can be achieved over an IF bandwidth of  $\sim 4$  GHz. Using InP HEMTs would reduce the IF noise contribution and increase the IF bandwidth to  $\sim 5$  GHz for the CfA receiver and  $\sim 8$  GHz for the NRAO receiver. These results are very encouraging and I am currently working on the design of a prototype integrated receiver using the CfA mixer and an FHR02X HEMT. This particular combination was chosen because the



components are available. If the prototype gives good results an obvious next step would be to replace the FHR02X HEMT with an InP device.

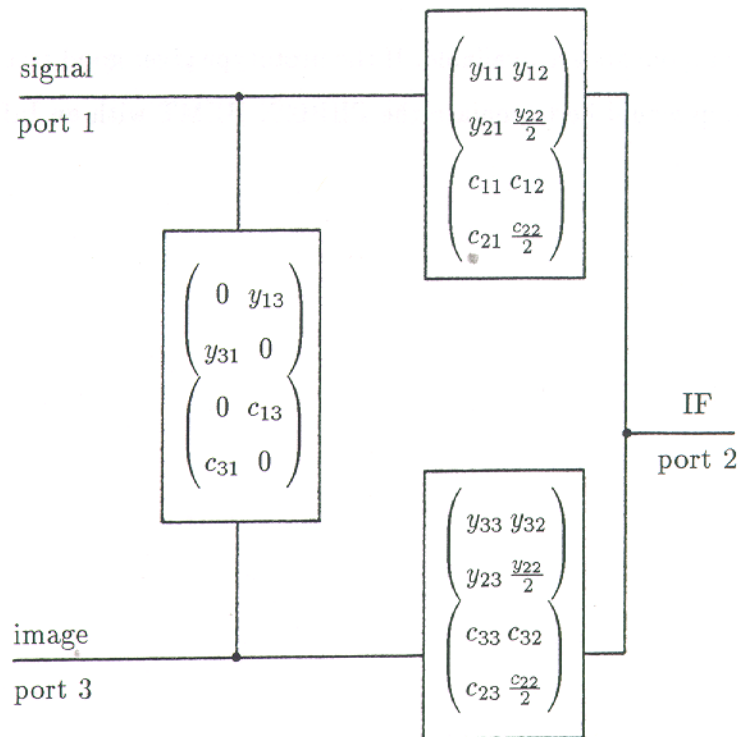

Fig. 1 Array of 2-ports used to synthesize a 3-port SIS junction model.  $y_{ij}$  and  $c_{ij}$  are the 3-port admittance and noise correlation matrix elements.

# SIS junction

GACIR  
MIXER

GOPT  
MIXER

NCIR  
MIXER

MMICAD -- Mon Mar 28 08:18:06 1994

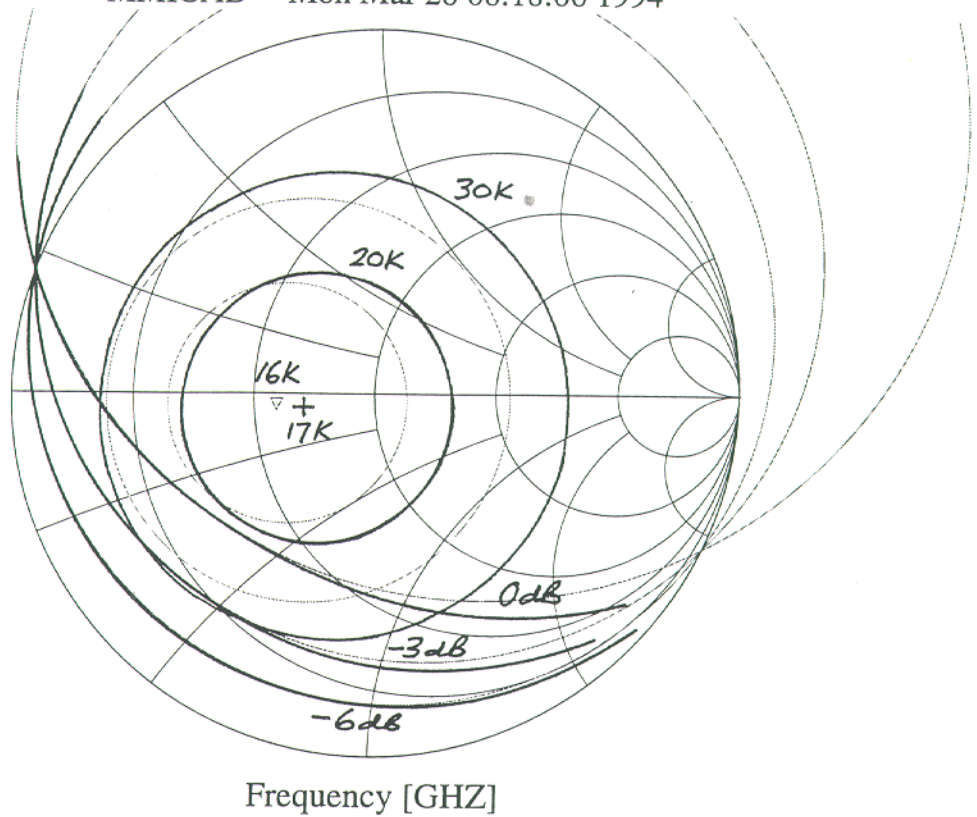
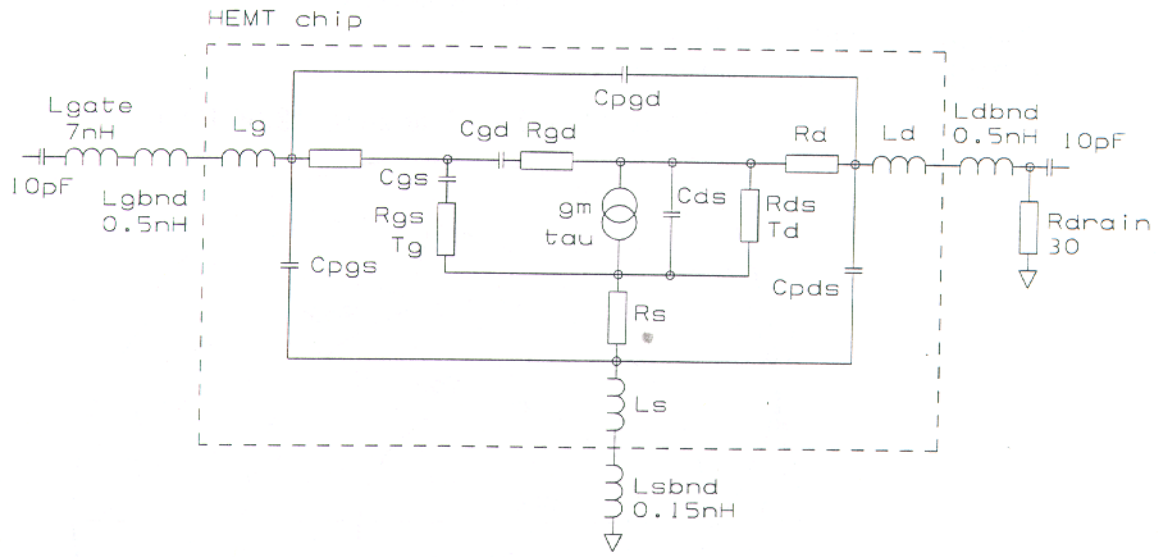

Fig. 2 Comparison of the MMICAD and Woody & Wengler SIS junction models. The Woody & Wengler noise and gain circles are bold, the MMICAD noise and gain circles are lighter.  $\nabla$  and + indicate the optimum signal impedance for the MMICAD and Woody & Wengler models respectively. The chart normalizing impedance is equal to the junction normal resistance and the image termination is also equal to the junction normal resistance.



	FHRO2X	InP		
		50um	300um	
INTRINSIC				
Cgs	190	37.7	266	fF
Rgs	4.5	4	0.7	ohm
Cga	26	2.9	17.4	fF
Rgd		400	67	ohm
gm	52	50.2	301	ms
tau	2	0.6	0.6	ps
Cds	47	5.2	31.2	fF
Rds	197	244	41	ohm
Tg	5	5	5	K
Td	523	400	400	K
PARASITIC				
Rg	0.5	3	3	ohm
Rd	1	12	12	ohm
Rs	0.5	8	8	ohm
Cpgs		6.5	39	fF
Cpgd		2.5	15	fF
Cpds		12	72	fF
Lg		33	33	pH
Ld		27	27	pH
Ls		6	6	pH

Fig. 3 Basic IF amplifier circuit and HEMT model parameters.



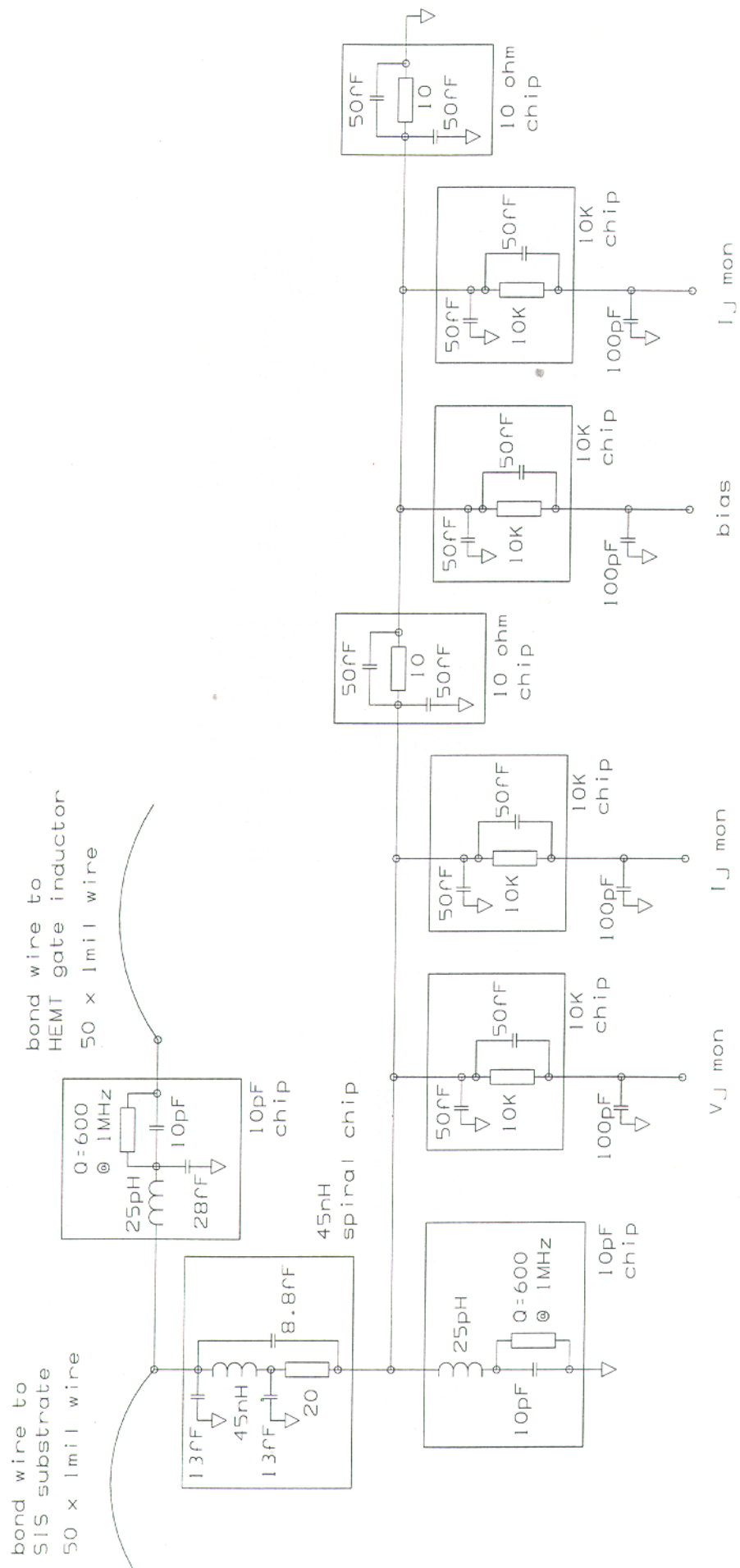

Fig. 4 Bias tee.

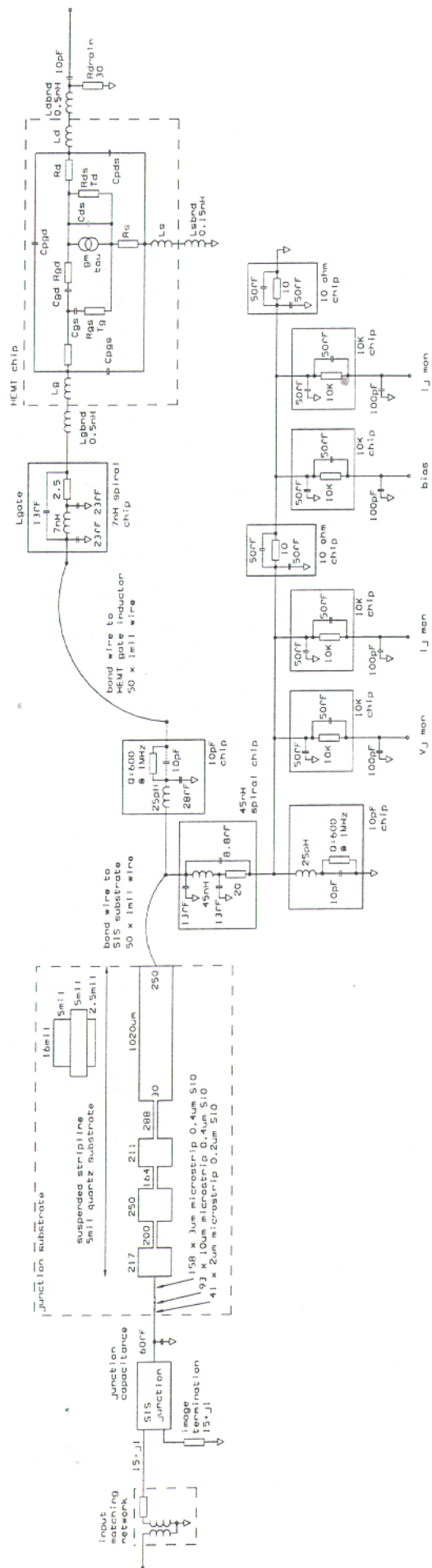

Fig. 5 CFA integrated receiver model.

### CfA mixer and FHR02X HEMT

TN      TMIN    MAG[S21]  
 SYSTEM   MIXER    SYSTEM

MMICAD -- Fri Mar 25 14:55:00 1994

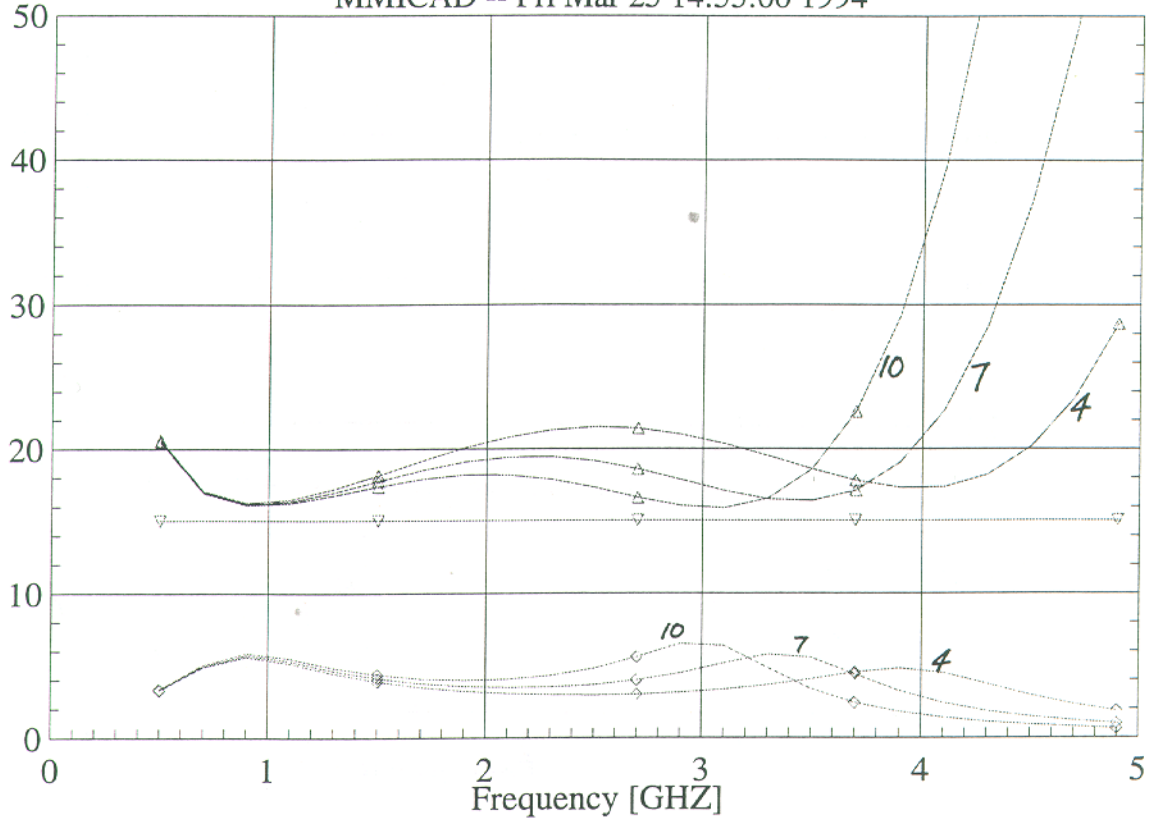

Fig. 6 Noise temperature and gain for the CfA integrated receiver with an FHR02X HEMT. The curve labels indicate the HEMT gate inductance in nH.

# CfA mixer and 300um InP HEMT

TN      TMIN    MAG[S21]  
SYSTEM MIXER    SYSTEM

MMICAD -- Fri Mar 25 15:00:58 1994

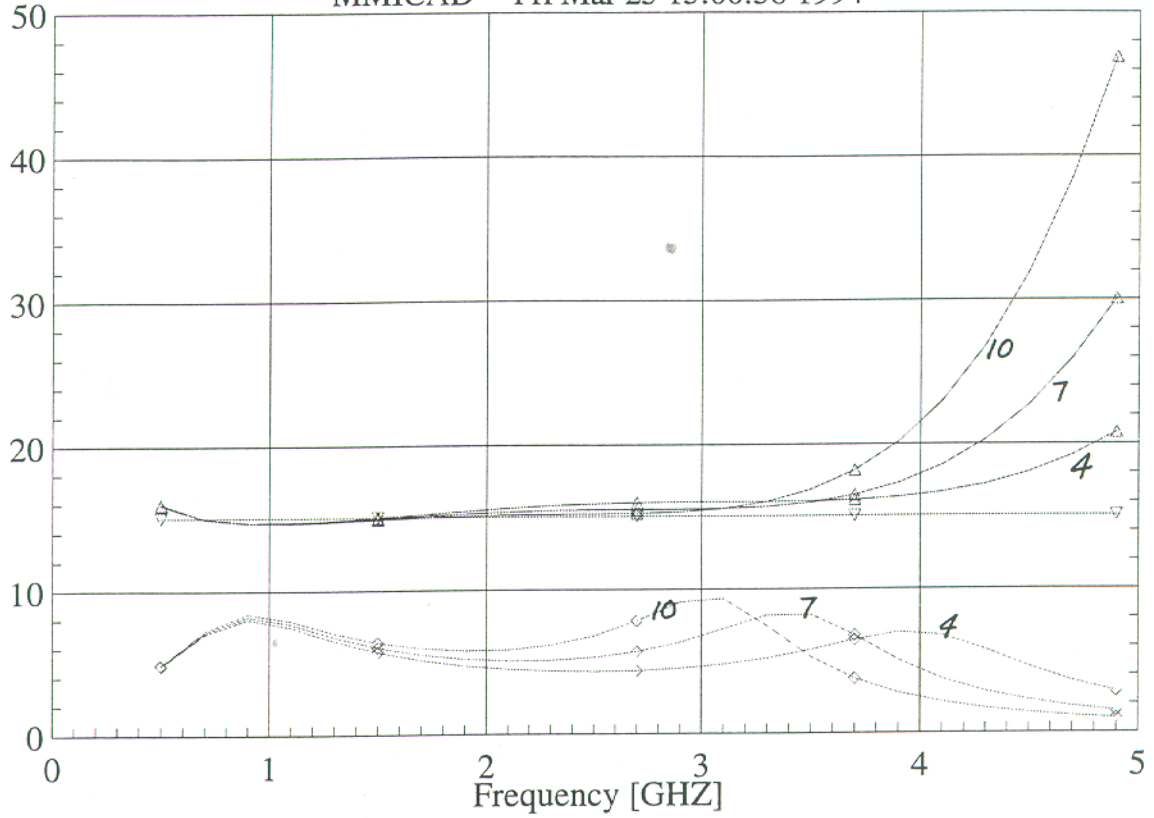

Fig. 7 Noise temperature and gain for the CfA integrated receiver with a 300  $\mu m$  InP HEMT. The curve labels indicate the HEMT gate inductance in nH.





# NRAO SIS373 mixer and FHR02X HEMT

TN      TMIN    MAG[S21]  
 SYSTEM   MIXER    SYSTEM

MMICAD -- Fri Mar 25 15:07:09 1994

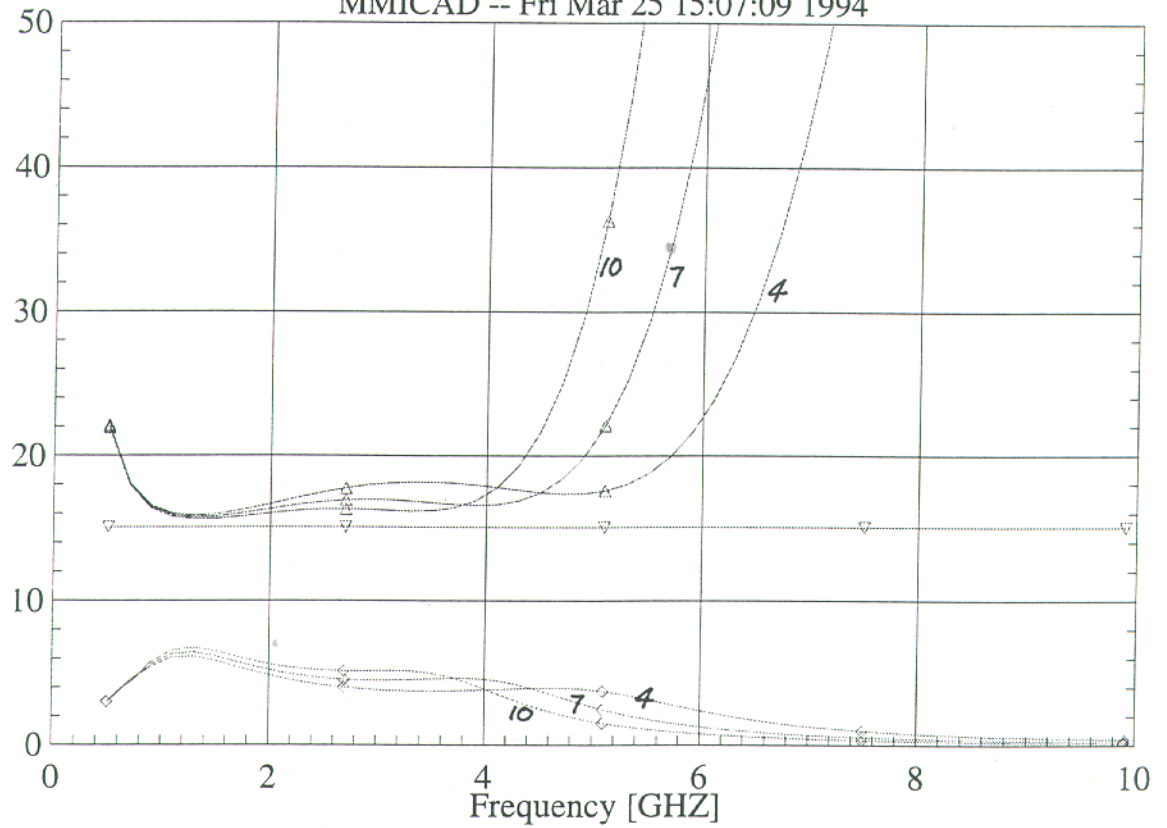

Fig. 9 Noise temperature and gain for the NRAO integrated receiver with an FHR02X HEMT. The curve labels indicate the HEMT gate inductance in nH.

# NRAO SIS373 mixer and 300um InP HEMT

TN      TMIN    MAG[S21]  
 SYSTEM MIXER    SYSTEM

MMICAD -- Fri Mar 25 15:08:12 1994

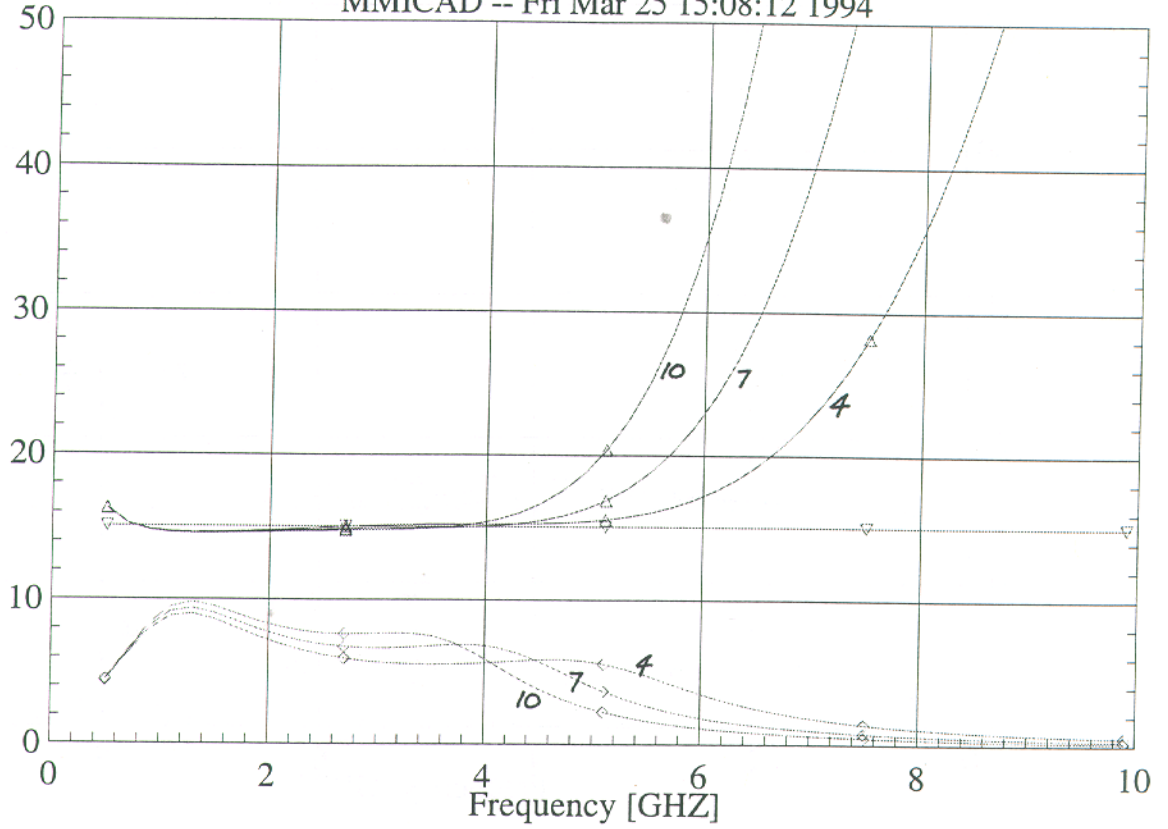

Fig. 10(a) Noise temperature and gain for the NRAO integrated receiver with a 300  $\mu\text{m}$  InP HEMT. The curve labels indicate the HEMT gate inductance in nH.

# NRAO SIS373 mixer and 50um InP HEMT

TN      TMIN    MAG[S21]  
 SYSTEM   MIXER   SYSTEM

MMICAD -- Fri Mar 25 15:09:01 1994

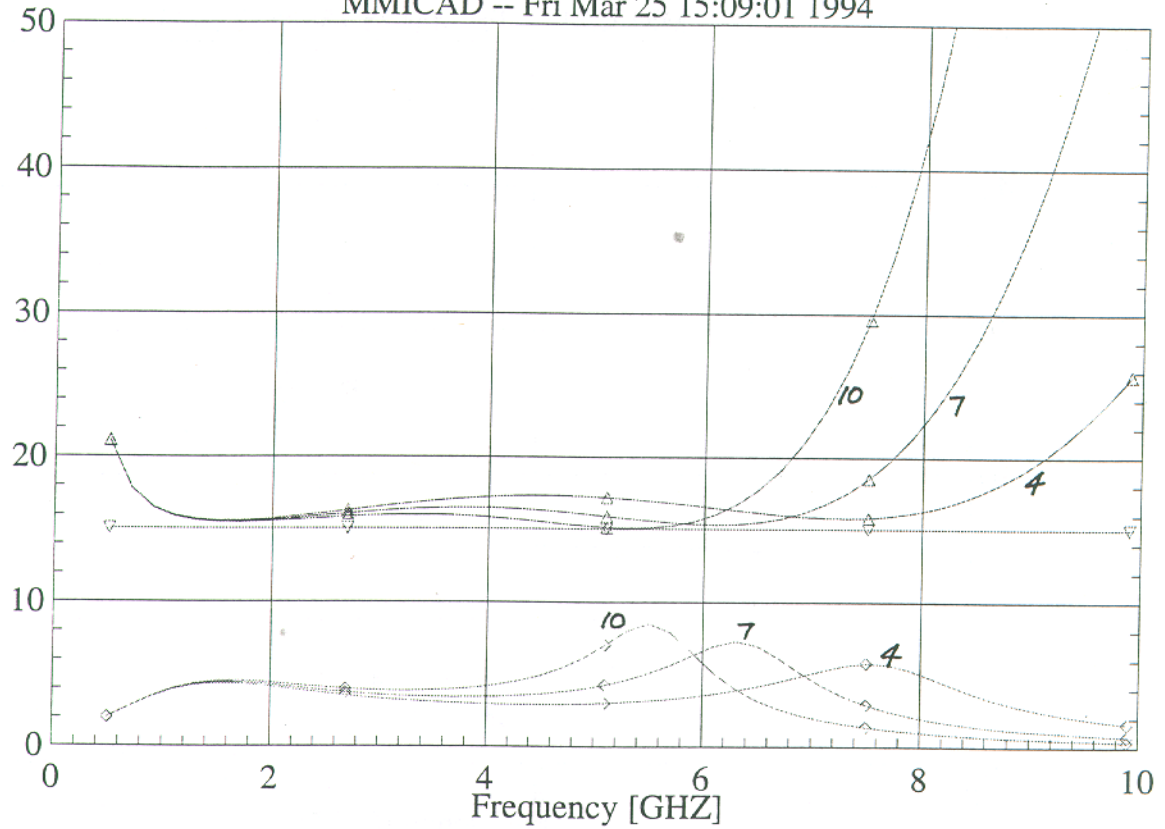

Fig. 10(b) Noise temperature and gain for the NRAO integrated receiver with a 50  $\mu m$  InP HEMT. The curve labels indicate the HEMT gate inductance in nH.